

LED drive and keyboard control chip CH455

English DataSheet

Version:1C

<http://wch.cn>

1. Introduction

CH455 is LED display drive and keyboard scan control chip. It sets clock surge circuit internally to drive four bits number LED or thirty two LEDs dynamically. And at the same time it can scan 28-key. CH455 exchanges data with MCU via two wires serial interface of SCL and SDA..

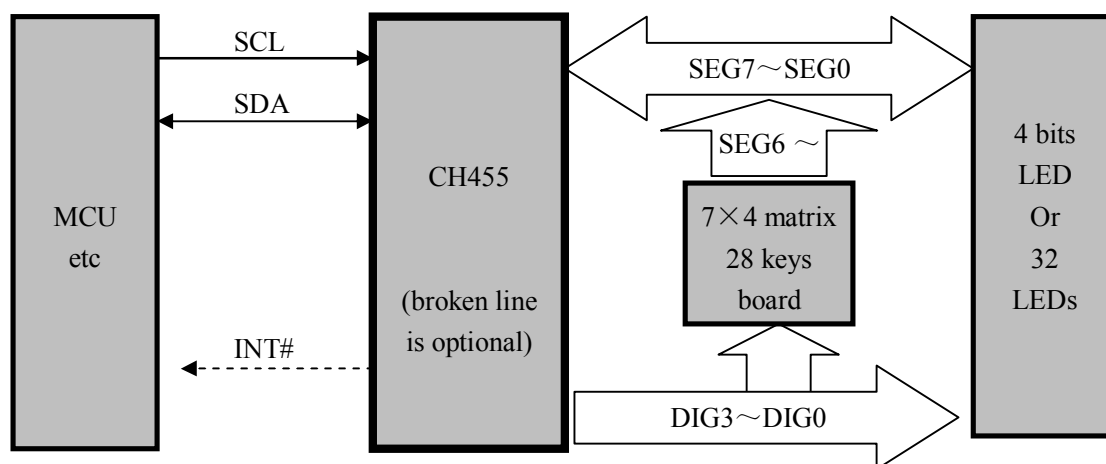

2. Features

- Set display current drive layer internally, the current of segment is no less than 25mA, the current of word is no less than 160mA.
- Display scan control dynamically, support 8×4 or 7×4 , directly drive four bits number LED or thirty two LEDs.
- Internal limit current, set eight level light control via space percentage.
- Set 28-key keyboard control, based on 7×4 matrix scan..
- Set pull-down resistor internal while key-press, glitter removable.
- Supply keyboard interrupt active with low-level, and supply key-press release token to check the key is pressed or release.
- High speed two wires serial interface, the speed of clock varies from 0 to 4MHz, compatible with I²C bus, save pins.
- Set turn on power to reset, 2.7V~5V power.
- Support low exhaust sleep mode to save energy, awoke via press key or command.
- Set clock surge circuit internally, the external clock or surge equipment is not necessary, resistor to be disturbed.
- Supply DIP18, SOP18 and SOP16 package without lead, compatible with RoHS, the function and pins are part compatible with CH450 .

3. Package

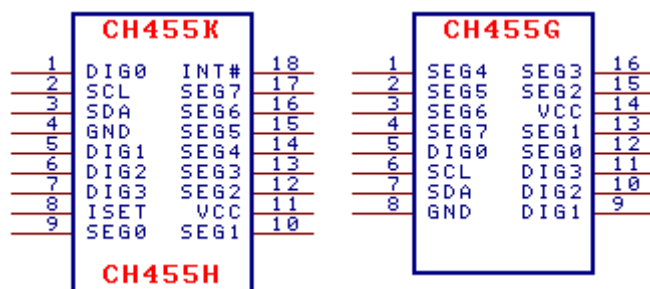

Package	Width of plastic		Pitch of pin		Instruction of package	Ordering
DIP18	7.62mm	300mil	2.54mm	100mil	Dual in-line package of 18-pin	CH455K
SOP18	7.62mm	300mil	1.27mm	50mil	Small outline package of 18-pin	CH455H
SOP16	3.9mm	150mil	1.27mm	50mil	Small outline package of 16-pin	CH455G

4. Pins

Pin No.		Pin Name	Type	Description
DIP18/SOP18	SOP16			
11	14	VCC	POWER	Positive power, the persistent current is no less than 150mA
4	8	GND	POWER	Public ground, the persistent current is no less than 150mA
9,10 12,13 14,15 16	12,13 15,16 1,2 3	SEG0 ~SEG6	Tri-state Output Input	Segment driver of LEDs, active with high level, Keyboard scan input, active with high level, with pull-down resistor
17	4	SEG7	Output	Radix point segment output of LED, active with high level, Key-board interrupt output in 7-segment mode, active with low level
1,5 6,7	5,9 10,11	DIG0 ~DIG3	Output	Word diver of LED, active with low level, Key-board scan output, active with high level
3	7	SDA	With pull-up resistor Drain-open output input	Data input and output of 2-wire serial interface, With pull-up resistor
2	6	SCL	input	Data clock of 2-wire serial interface, With pull-up resistor
18	No	INT#	With	Key-board interrupt output, active with

			pull-up resister Drain-open output	low-level
8	No	ISET	Input	Adjust the upper limit of segment current, NC. Means the default setting

5. Function description

5.1. General description

The data in this manual has three types. Binary numbers are followed by a “B”. Hexadecimal numbers are followed by an “H”. Numbers without annotations are decimals. X stands for any value.

MCU (DSP, microprocessor etc. controller) controls CH455 chip via 2-wire serial interface. The numeric display driver is independent of keyboard scan control, so the MCU can start, close, set the two functions separately. The 2-wire serial interface of CH455 is achieved by hardware, and the MCU can high-speed operate on the serial interface frequently, the efficient of CH455 has no influence.

5.2. Display driver

CH455 adopts dynamic scan to drive the numeric LED and LED, the sequence is from DIG0 to DIG3. When one pin draws the current, the other pins don't draw current. In the internal, CH455 has current drive layer to directly drive 0.5 inch to 1 inch common cathode, segment drive pin SEG6~SEG0 are each responding to segment G~A of number LED. SEG7 is radix point. Word drive pin DIG3~DIG0 connect to four numeric LEDs' cathode respectively. CH455 can connect to LED which is 8×4matrix or thirty two separate LEDs. Or connect to common anode number LED through inverter driver. Otherwise connect to large size number LED via high-power pipe. In 7-segment mode, SEG7 is used as keyboard interrupt output, and can't drive the radix point.

The numeric LED display drive time is divided by eight, supports eight layers light control by setting the space rate. The space rate is from 1/8 to 8/8. The space rate is more greater, the drive current of numeric LED is more bigger, and the display light is more higher. The space rate is not linear with display light.

There four data registers with 8-bit in CH455, used to save four words data, corresponding to four numeric LEDs or four groups which group has eight LEDs. The bit7 to bit0 is corresponding to radix point and segment G to segment A. For the LED array, the data bit of each word is corresponding to one LED. When the data bit is 1, the segment or LED of corresponding numeric LED is light; when the data bit is 0, the segment or LED of corresponding numeric will distinguish. For example, the bit 0 of the third data register is 1, the segment A of the third numeric LED will light.

The following is segment name of number LED.



5.3. Keyboard scan

The function of keyboard scan supports 28-key keyboard which is 7×4 matrix. During the keyboard scan period, DIG3 to DIG0 are used to column scan output, the pins of SEG6 to SEG0 are all have pull-down resistor internal, used to row scan input.

CH455 insert the keyboard scan regularly during display drive scan. During keyboard scan, DIG3 to DIG0 output high level in turns according DIG0 to DIG3, the other pins output low level; the output of SEG6~SEG0 are forbidden, when there is no key pressed, SEG6~SEG0 are pulled to low level; when there is a key pressed, such as the key connect DIG1 to SEG4 is pressed, DIG1 output high level and SEG4 has checked high level; in order to avoid the environment, CH455 will scan twice, and once the two result is the same, the key press is efficient. If CH455 has checked the efficient key-press, take a record of the key-press code, and generate the keyboard interrupt which active with low level via INT#, at the same time, MCU can read the key-press code via serial interface; before checking the efficient key-press, CH455 will not generate any keyboard interrupt. CH455 doesn't support the assembled key-press; it means that, two keys or more keys can not be pressed at the same time. CH455 supports combination key of SEG1 and SEG0 for the same DIG, the combination key has the priority. In additional, if two keys or more keys are pressed, the key with lower code has the priority. For example, the two keys which connection of DIG1 with SEG1, and connection of DIG1 and SEG0, are combination key.

The key-press code supplied by CH455 has 8 bits, the bit-7 is always 0 and bit-2 is 1, bit1 to bit 0 is column scan code, bit5 to bit3 is row scan code, bit 6 is state code (press key is 1, release key is 0). For example, the key connects DIG1 to SEG4 is pressed, the key-press code is 01100101B or 65H, when the key is released, the key-press code is 00100101B or 25H (maybe is other code, but the value is lower than 40H). The column scan code is 01B responding to DIG1, the row scan code is 100B responding to SEG4. MCU can read the key-press code at any time, in generally, after checking the efficient key-press, generating keyboard interrupt, then read the key-press code. At this time, the bit6 is always 1. MCU can read the key-press code via check mode to know when the key is released, till the bit6 is 0.

The following table is key-press address of DIG3~DIG0 and SEG6~SEG0, also is numeric LED segment bit and LED array address. The key-press code is 8-bit, the bit-6 is always 1 when press key. When key is pressed, the actual key-press code is the following address adds 40H, it means that the key-press code is between 44H and 77H.

address	DIG3	DIG2	DIG1	DIG0				
SEG0	07H	06H	05H	04H				
SEG1	0FH	0EH	0DH	0CH				
SEG2	17H	16H	15H	14H				
SEG3	1FH	1EH	1DH	1CH				
SEG4	27H	26H	25H	24H				
SEG5	2FH	2EH	2DH	2CH				

SEG6	37H	36H	35H	34H				
SEG0+SEG1	3FH	3EH	3DH	3CH				

5.4. Serial interface

CH455 has 2-wire serial interface achieved by hardware, contains two main signal wires: serial data clock input wire SCL, serial data input and output wire SDA; and one assistant signal wire: interrupt output wire INT#. The SCL is input wire with pull-up resistor, high-level in default; SDA is bidirectional signal wire with pull-up resistor, high-level in default; INT# is drain open output with pull-up resistor, after starting keyboard scan function, it is keyboard interrupt output, high-level in default.

SDA used to input and output serial data, high-level means bit data is 1, low-level means bit data is 0, the serial data input sequence is high bit in front, and the low bit is behind.

SCL used to supply serial clock. CH455 input data from SDA when SCL is raising, output data from SDA when SCL is falling.

During SCL is high-level, the SDA is falling, defined as start signal of serial interface. During SCL is high-level, the SDA is raising, defined as stop signal of serial interface. After CH455 has checked start signal, it can receive and analyse command. In order to save I/O pin, keep SDA state, share the SCL with other interface circuit; if make sure the SDA change only when SCL is low-level, SCL and SDA can share with other interface circuit.

INT# used as keyboard interrupt output, high-level in default. When CH455 has checked the efficient key-press, INT# output interrupt active with low-level; after MCU is interrupted, execute read operation to CH455, CH455 will change INT# to high-level, and output key-press code from SDA, MCU gets one byte data from SDA, key-press code.

The communication process has six steps: output start signal, output byte 1, acknowledge 1, input byte 2, acknowledge 2, output stop signal. The start signal and the stop signal are as before, acknowledge 1 and 2 are always 1, the output byte 1 and input byte 2 each contains 8-bit data bits, one byte data.

The following is a write operation, byte 1 is 01001000B, 48H; byte 2 is 00000001B, 01H.

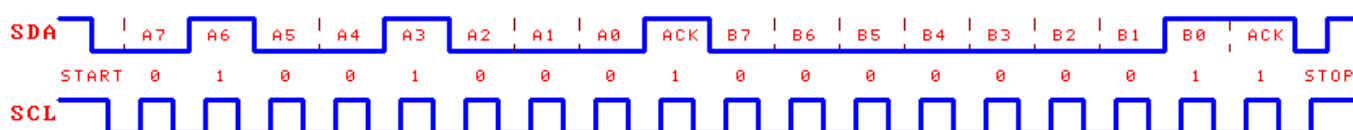

6. Operation command

The operation command of CH455 is divided as three groups. The start command, stop command, acknowledge 1 and acknowledge 2 are the same, the difference are the output byte 1, byte 2, the transfer direction of byte 2.

6.1. Set system parameter command

The output byte is 01001000B, 48H; the output byte 2 is 0[INTENS][7SEG][SLEEP]0[ENA]B.

The set system parameter command is used to set CH455 system layer parameters: display and keyboard scan enable ENA, sleep enable SLEEP, 7-segment mode 7SEG, display light control INTENS. The command has no influence on the data in internal data buffer.

When ENA is 1, allow display output and keyboard scan; when ENA is 0, close display drive and

keyboard scan.

When SLEEP is 1, CH455 enter into low-power exhaust sleep state to save power. CH455 can be woken by one of the two affairs: one is checked the key-press of SEG0~SEG3, the efficient key-press code id from 44H to 5FH; the other is received the next operation command from MCU. When CH455 has been woken up, the SLEEP will automatic clear as 0. The operation of sleep and awake has no influence on CH455's other work sate. If ENA is 1, awake and then generate key-press interrupt; if ENA is 0, awake and don't generate key-press interrupt.

When 7SEG is 1, responding to 7-segment mode, display scan is 7×4 , don't support radix point. SEG7 used as key-press interrupt output, the same efficient with INT#. When 7SEG is 0, responding to 8-segment mode, display scan is 8×4 , support radix point. This bit is used to CH455G to start key-board scan function without INT# pin.

The display light INTENS via 3 bits data to control. 001B to 111B and 000B set the display drive space rate is 1/8 to 7/8 and 8/8, the default value is 8/8.

For example, byte 2 0000001B indicates the mode is 8-segment, display space rate is 8/8; byte 2 0100001B indicates the mode is 8-segment, display space rate is 4/8; byte 2 00001001B indicates the mode is 7-segment, display space rate is 8/8; byte 2 00000100B indicates enter into low-power sleep mode, woke up by press key or command operation, SLEEP clear as 0.

6.2. Load word data command

The output byte 1 of this command is address 68H, 6AH, 6CH or 6EH, responding to four numeric LEDs DIG0~DIG3; the output byte 2 is [DIG_DATA]B, and the value is between 00H to 0FFH, eight bits data word.

The load word data command is used to write word data DIG_DATA to data register whose address is appointed by byte 1. For example, command data 01101100B (6CH responding to DIG2), 01111001B means write word data 79H to the first data register, make the numeric LEDs display **E** which is driven by DIG2.

6.3. Read key-press code command

The output byte 1 of this command is 01001111B, 4FH; the input byte 2 is key-press code.

Read key-press code command is used to get the efficient key-press code which is checked by CH455. This command is read operation, only has data return command. The MCU must release SDA pin (tri-state output forbid or pull-up to high-level), then CH455 output key-press code from SDA, the efficient data bit id bit7 to bit0 of key-press, bit6 is state code, bit5~bit0 is scan code and key-press address.

7. Parameter

7.1. Absolute maximum rating (Stresses above those listed can cause permanent damage to the device. Exposure to maximum rated conditions can affect device operation and reliability.)

Name	Parameter note	Min.	Max.	Units
TA	Ambient operating temperature			°C
	ISET connects to ground, connect limit current resistor	-40	85	
	Don't connect limit current resistor, using internal limit current	-40	70	

TS	Storage temperature	-55	125	°C
VCC	Voltage source (VCC connects to power, GND to ground)	-0.5	6.5	V
VIO	The voltage of input or output pin	-0.5	VCC+0.5	V
IMdig	Sequential driven current of signal DIG pin	0	200	mA
IMseg	Sequential driven current of signal SEG	0	40	mA
IMall	The total of all SEG pins sequential driven current	0	130	mA

7.2. Electrical parameter (test conditions: TA=25°C, VCC=5V)

Name	Parameter note	Min.	Typical	Max.	Units
VCC	Source voltage	2.7	5	5.3	V
ICC	Source current	0.2	80	150	mA
ICCs	Static current (SCL, SDA and INT# are high-level)		0.05	0.15	mA
ICCsIp	Sleep current (SCL, SDA and INT# are high-level)		0.006	0.02	mA
VIL	SCL and SDA are low-level input voltage	-0.5		0.8	V
VIH	SCL and SDA are high-level input voltage	2.0		VCC+0.5	V
VILseg	SEG low-level input voltage	-0.5		0.5	V
VIHseg	SEG high-level input voltage	1.8		VCC+0.5	V
VOLdigx	DIG pin is low-level output voltage (-200mA)			1.2	V
VOLdig	DIG pin is low-level output voltage (-100mA)			0.8	V
VOHdig	DIG pin is high-level output voltage (5mA)	4.5			V
VOLsegx	SEG pin is low-level output voltage (-40mA)			1.0	V
VOLseg	SEG pin is low-level output voltage (-20mA)			0.5	V
VOHseg	SEG pin is high-level output voltage (20mA)	4.5			V
VOL	Other pins low-level output voltage (-4mA)			0.5	V
VOH	Other pins high-level output voltage (4mA)	4.5			V
IDN1	Input pull-down current of SEG pin	-30	-50	-400	uA
IUP1	Input pull-up current of SCL pin	10	200	300	uA
IUP2	Input pull-up current of SDA pin	150	300	500	uA
IUP3	Input pull-up current of INT# pin	500	2000	5000	uA
VR	Default restrict voltage when power-up reset	2.2	2.4	2.6	V

7.3. Internal sequence parameter (test conditions: TA=25°C, VCC=5V)

(note: the sequence parameter in this table is multiple of inner clock cycle, the frequency of inner clock will reduce while source power falls.)

Name	Parameter note	Min.	Typical	Max.	Units
TPR	Reset time generated by power-up detection	10	25	60	mS
TDP	Display scan cycle	4	8	20	mS
TKS	Key-board scan interval, key-press acknowledge time	20	40	80	mS

7.4. Interface sequence parameter (test conditions: TA=25°C, VCC=5V, consult the following image)

(note: the unit is 10^{-9} mainly, the max value which is not given clear indication is infinite in the abstract.)

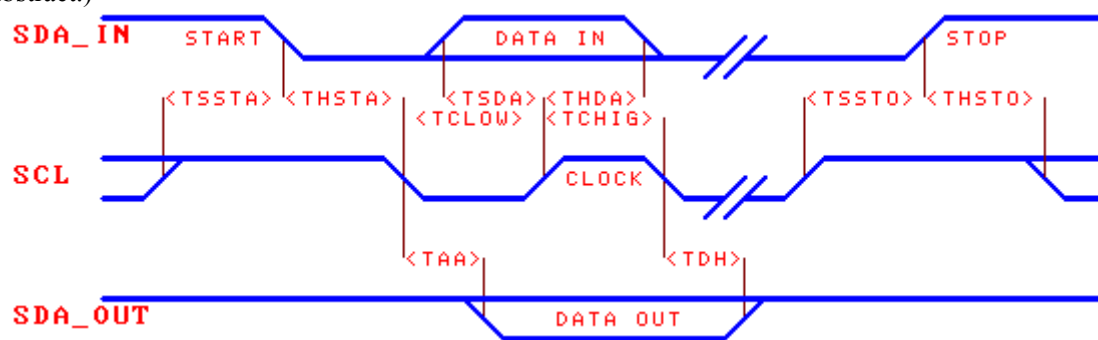

Name	Parameter note	Min.	Typical	Max.	Units
TSSTA	Start signal set up time when SDA is falling edge	100			nS
THSTA	Start signal keep time when SDA is falling edge	100			nS
TSSTO	Stop signal set up time when SDA is rising edge	100			nS
THSTO	Stop signal keep time when SDA is rising edge	100			nS
TCLOW	Low-level width of SCL clock signal	100			nS
TCHIG	High-level width of SCL clock signal	100			nS
TSDA	SDA input data for SCL rising edge set up time	30			nS
THDA	SDA input data for SCL rising edge keep time	10			nS
TAA	SDA output data efficient for SCL falling edge delay time	2		30	nS
TDH	SDA output data inefficient for SCL falling edge delay time	2		40	
Rate	Average data transform speed	0		4M	bps

8. Application

8.1. Numeric LEDs driver and key-board scan (following image)

CH455 connects to the external MCU via two wires serial interface SCL and SDA.

Capacitance C1 and C2 are laying next to power pin, used to power decoupling decrease the disturb generated by driven large current.

CH455 can directly drive four common cathodes dynamically. The same segment pin (segment A~G and radix point) of all the number LED parallel connect, then connect to SEG0~SEG7 of CH453 via serial connect limited current resistor R1. The public cathode of each number LED is driven by DIG0~DIG3 of CH455. ISET pin connects to ground, close internal limited current, so connect R1 to limit and balance segment driver current. On the 5V power, usually serial connects 200Ω resistor is corresponding to 13mA segment current. The value of limited current resistor is more larger, the segment current is more smaller, the display light is more darker. The value of R1 is between 50Ω and 1KΩ, when the power voltage is lower (such as VCC=3.3V), don't need limited resistor. While the other condition is the same, select the large value resistor at priority to reduce consume of CH455.

CH455 has key-board scan function with 28-key. If only need few key-press, get rid of any key-press in 7×4 matrix. In order to avoid influence on display because of the short circuit of SEG and DIG signal wire after key-press, serial connect limit current resistor R11-R14 between DIG0~DIG3 and keyboard matrix, the value is from 1KΩ to 10KΩ. When use keyboard function,

the INT# of CH455 can connect to input pin or common I/O pin of MCU.

In the image, the MCU U2 via CH455 drives four common cathode numeric LEDs and scan twenty eight keys. Because some numeric LED has reverse creepage when the voltage is high, make a mistake for CH455 that there is one key is pressed for a long time, recommend to use diode D1-D4, and enhance input signal level of SEG0~SEG6 when keyboard scan. When source voltage is low (such as 3.3V), get rid of these diodes to avoid influence on the display light.

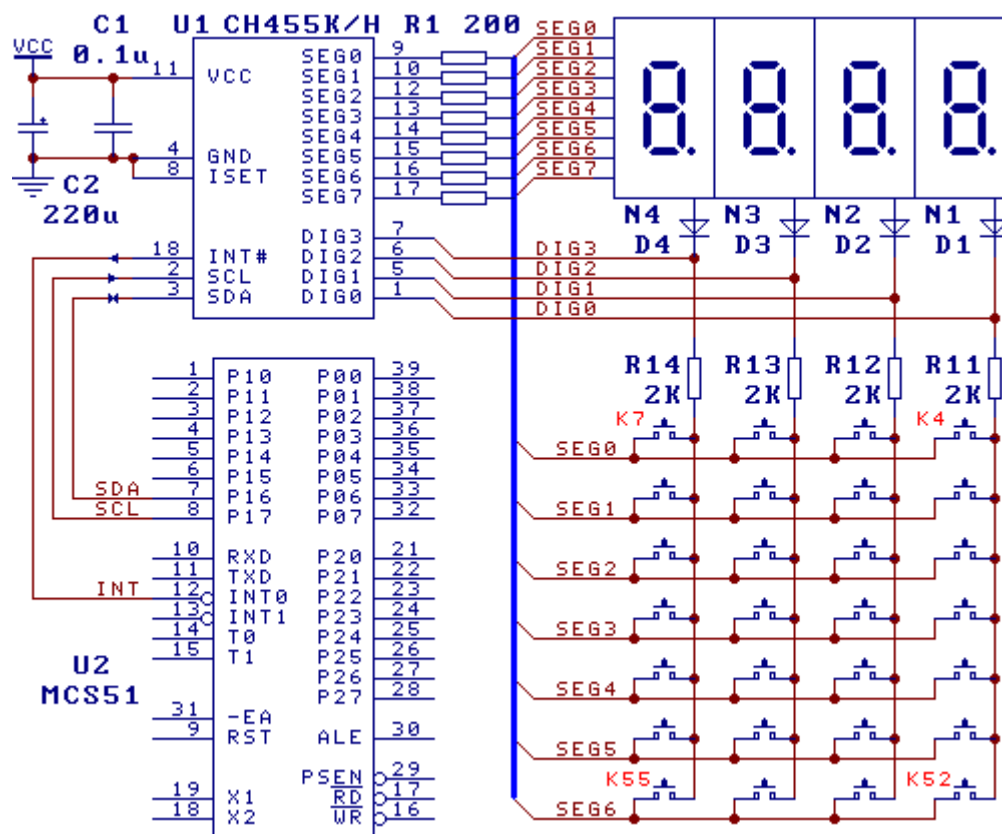

8.2. Drive common anticathode numeric LEDs (following image)

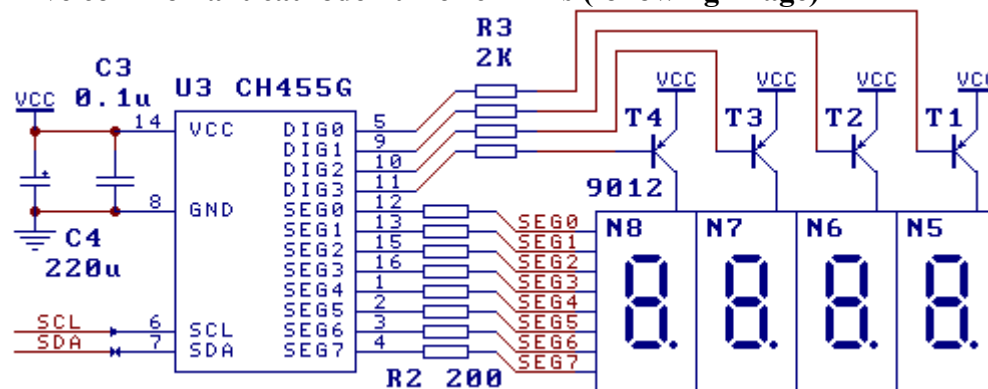

After adding reversers in DIG0~DIG3 word pins, CH455 can drive common anticathode numeric LEDs. In the image, the reversers are composed of four PNP audions T1~T4 (type of 9012 or 8550) and four resistors R3 (1KΩ to 3KΩ), drive four common anticathode numeric. The SEG segment is converse drive in this connection, so the word data in load word data command

must be opposite by bit, when the data bit is 0, light; when the data bit is 1, extinguish. There is no current limit in the chip when reverse drive.

If want to drive large size numeric LEDs with high voltage or add drive current to enhance light, consult the detail of CH452.

8.3. Application: 7-segment $\times 4 + 7$ -key

For CH455G with SOP16 package, without INT# press key interrupt output pin, if need key-press scan function, there are two methods : one is start 7-segment mode, don't drive radix point of numeric LEDs, use SEG7 as key-press interrupt output; the other is use 8-segment mode, MCU to query whether key is pressed after read key value regularly.

The following image is about the former mode, support four numeric LEDs 7-segment and 7-key without radix point. It is Using SEG7 as key-press interrupt output, and using internal current limit, to save outside segment current limit resister. In the image, it is using 7-key-press, get rid of three resister of DIG pin, in actually, the R10 can also be remove, when the key is pressed, one numeric LEDs one segment will extinguish, until the pressed key is released, it will recover.

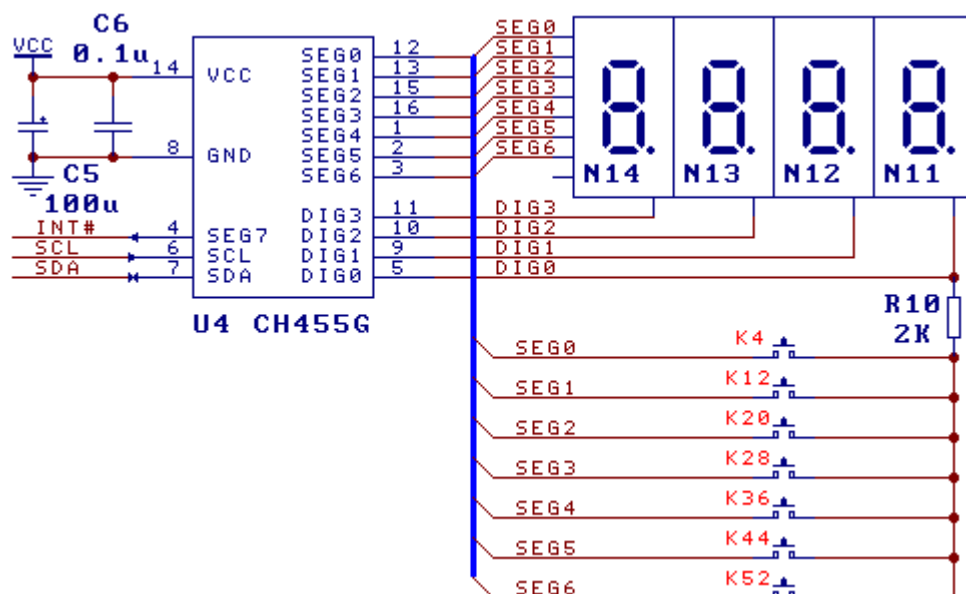

8.4. Application: 7-segment $\times 4 + 4$ -key

Following image is another application, support four numeric LEDs and four key-press 7-segment without radix point. The SEG0 is used as input, SEG7~SEG1 are used to drive segment G to segment A of numeric LEDs. Left shift one bit when loading word data.

ISET used to set segment drive current, suspend in default. Enhance the voltage of ISET pin, the segment current will reduce. Reduce the voltage of ISET pin, the segment current will be enhanced.

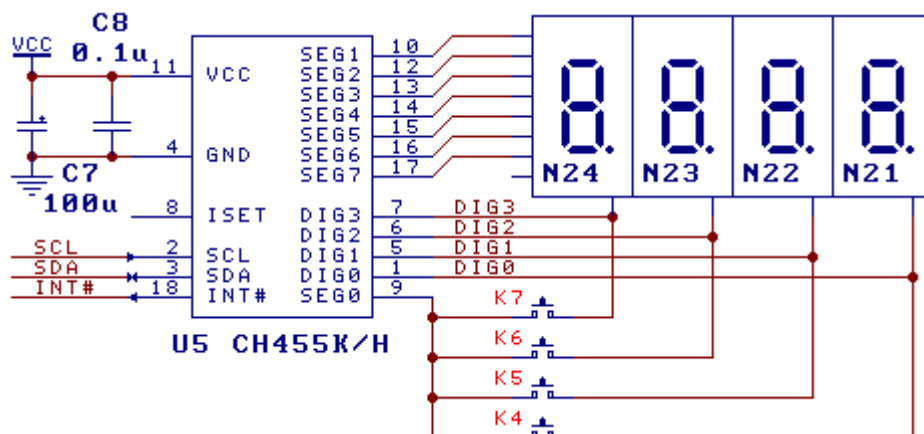

8.5. Anti-jamming (important)

Because current of CH455 drives number LED or LED is large, burr voltage will generated in power. If power wire or ground wire doesn't lay logically, it will influence stability of MCU or CH455. The resolve methods of power jamming are as following:

①, Recommending to use the short and thick power wire and ground wire, especially when CH455 and MCU are belongs to two PCBs;

②, Near to CH455, and between positive and negative power to parallel connection power decoupling capacitance, One 0.1uF monolithic or china capacitance and no less than 100uF electrolytic capacitance are at least.

For the long signal wire, consult the following image:

①, Add capacitance C11 and C12, near to CH455 of signal wire, the capacitance is from 47pF to 470pF. The capacitance is more large, the transfer speed of MCU communication is more slower;

②, Add R18 and R19 are optional, the value is from 100Ω to 470Ω;

③, Depress the transfer speed between MCU and CH455 (because of adding the capacitance and resister);

④, Drive by standard I/O pin (such as standard MCS51 MCU), recommend to add R8 and R9, the value is from 500Ω to 10KΩ, to enhance the pull-up ability of MCS-51 I/O pins, in that case to keep the better digital signal wave; when the signal wire is short, the R8 and R9 is no need. For I/O pins with totem pole drive, the R8 and R9 are no need.

Addition, In the strong disturb environment, MCU can refurbish CH455 several seconds termly. Containing newly load data register of each number LED and newly start displaying.

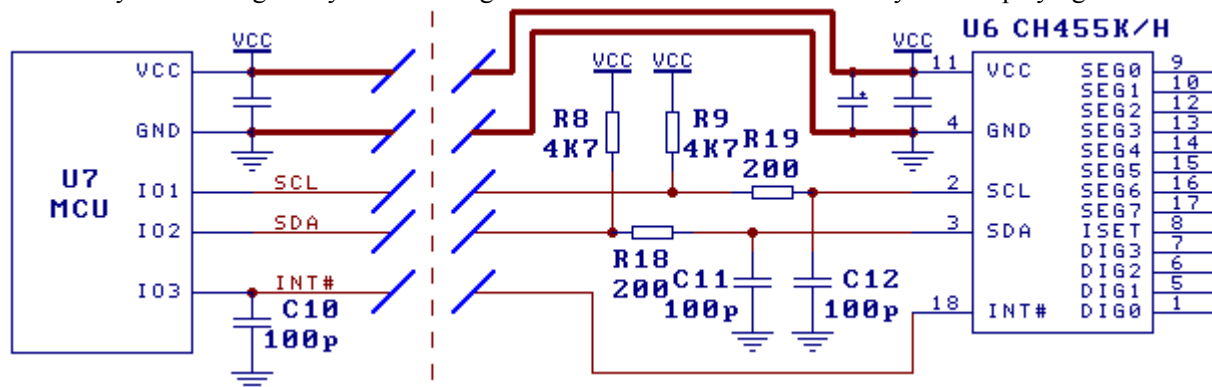

8.6. MCU interface program

The program of CH455 is compatible with CH450, using the subprogram and example subprogram of CH450 directly, some C language and ASM interface program is offered in the www.wch.cn web.

For four bits numeric LEDs, CH455K with DIP18/SOP18 package and CH450K with DIP20/SOP20 are basically compatible in pins, only use DIG4~DIG7 and the right end are together of 18-pin package and 20-pin package.